

## BOAT REVIEW

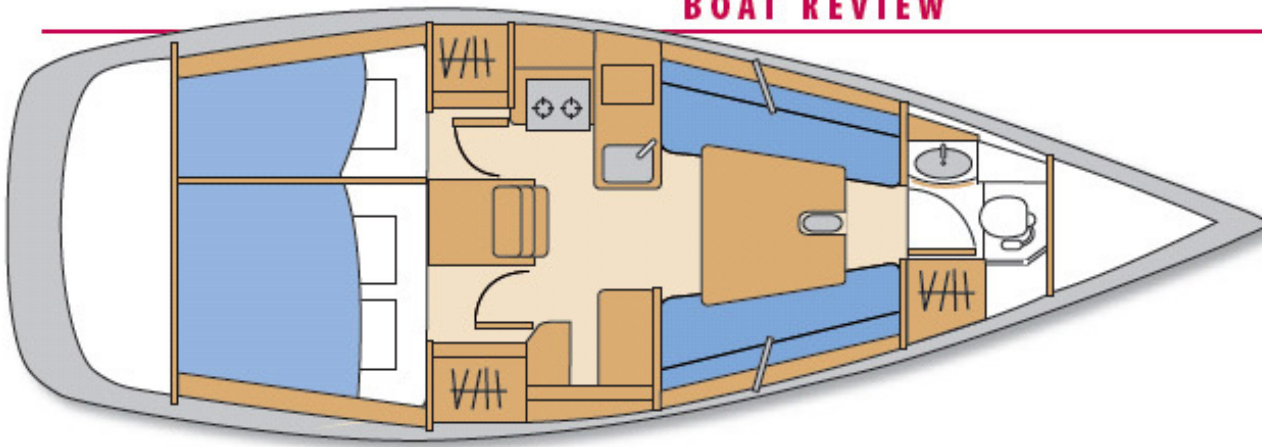

*The Beneteau 10R's layout puts the head forward, where it serves as a snag-free and splash-proof pit for launching and dousing the spinnaker. The strut-and-bulb T-keel (right) concentrates ballast and helps minimize wetted surface, but it can pose an attractive "hook" for speed-robbing weed. The design ratios (below) suggest that the 10R will compete well with the J/109, while the J/105 should have an edge in light airs.*

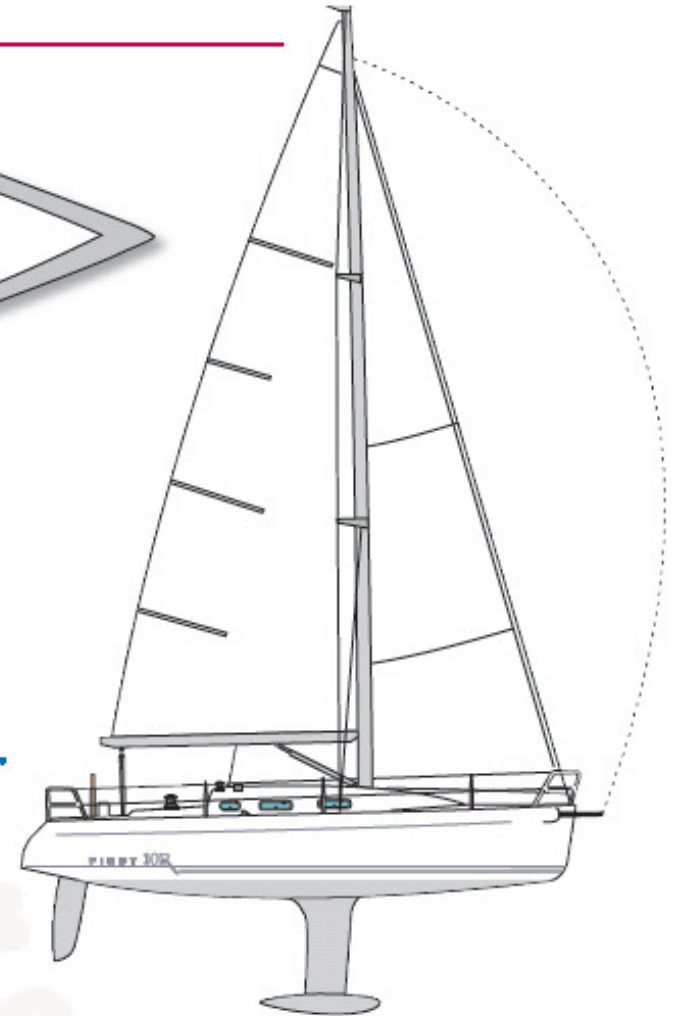

### BENETEAU FIRST 10R IN CONTEXT

	BENETEAU FIRST 10R	J/105	J/109
LOA	32'9"	34' 6"	35' 3"
LWL	28' 8"	29' 6"	30' 6"
Beam	11'	11'	11' 6"
Draft (shoal)	6' 7"	6' 6" (5' 6")	7' (5' 9")



<b>Displacement</b>	9,715 lbs.	7,750 lbs.	10,900 lbs.
<b>Ballast</b>	3,693lbs.	3,400 lbs.	3,900 lbs.
<b>Sail area (100%)</b>	570 sq. ft.	577 sq. ft.	644 sq. ft.
<b>Engine</b>	20 hp.	20 hp.	29 hp.
<b>Water</b>	26 gal.	20 gal.	35 gal.
<b>Fuel</b>	20 gal.	12 gal.	20 gal.
<b>SA/D ratio</b>	19.3	24	21
<b>D/L ratio</b>	208	135	172
<b>Price</b>	\$136,000	\$139,375	\$212,750